



# ALCHEMY 5

THE NEW-GENERATION LED WASH LIGHT, MADE FOR ANY TASKS WHERE COLOR PERFECTION IS PARAMOUNT



**6-COLOR LED SOURCE**  
COUPLED WITH Ø 250 MM FRESNEL LENS  
AND A 10° - 47° LINEAR ZOOM

**HIGH LUMINOSITY WITH AN EVENLY  
DIFFUSED AND FLAT BEAM**

**SUPERIOR WHITE LIGHT QUALITY  
AND ACCURATE COLOR RENDERING**

**EXTENDED COLOR PALETTE**

**WIDE GAMUT OF PASTEL-LIKE COLORS**

**LINEAR CTC TO MEET CAMERA  
OR PRODUCTION REQUESTS**

**SILENT MODE:  
EXTRA-QUIET OPERATION DESIGNED  
FOR THEATRES AND TV STUDIOS**



# PRELIMINARY INFORMATION

## OUTPUT

- 6-color chip LED source
- 9,800 Lumen output
- LED lifespan: 50,000 hours (70% lumen output)

## OPTICAL GROUP

- 10°- 47° linear zoom
- Ø 250 mm Fresnel lens
- Beam shaper with 360° indexing and endless rotation

## COLOR GENERATION

- Linear CTC
- 16 million colors
- Full control of color synthesis
- Color mixing by RGB, CMY and HSI standards, or by 'Raw' mode (6 color channels management)

- Green – Magenta linear balance, for a natural reproduction of any skin tone
- 100 ready-made gel filter emulations
- Linear shift from white to any gel filter emulation
- 'Hi-Q Dimming' technology

## CONTROL

- LCD graphic display + 4 soft-keys; Auto-flip; Key-Lock function
- Art-Net 4, sACN, RDM/DMX protocols
- Controlled via DMX 512 / RDM standard digital communication protocols
- "Standard" and "Silent" operation modes

- Internal operating system updatable via DTS dongle firmware uploader

## DMX

- 6 DMX modes

## PAN & TILT

- Pan 540°
- Tilt 220°
- 16-bit resolution
- 4 Selectable speed ranges
- Pan / Tilt lock

## POWER SUPPLY

- Electronic full-range 100-240Vac 50-60 Hz
- Power consumption: 450 W max
- Power Factor: PF >0.90

## CONNECTIONS

- Power supply: PowerCON TRUE1 In/Out panel connectors
- DMX: XLR 3-pole and 5-pole In/Out panel connectors
- Art-Net / sACN: etherCON RJ45 connector

## INTERNAL SAFETY DEVICES

Overvoltage and overtemperature circuits protection

## OPERATING TEMPERATURE

-10° / 40° C

## PHYSICAL

- IP20
- Weight: 26 Kg (57.5 lbs)
- Finishing: Black

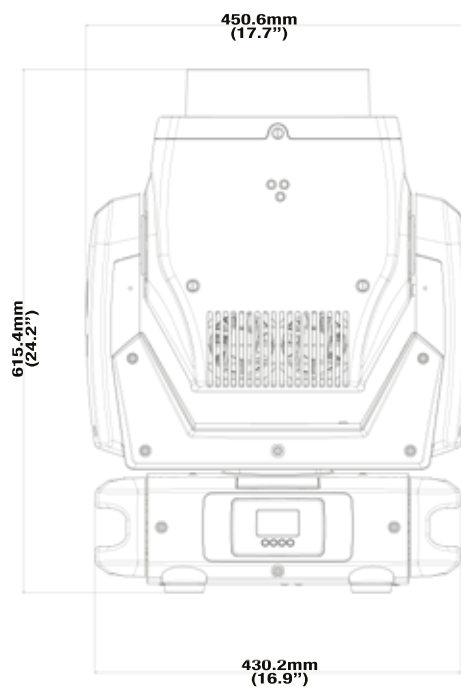
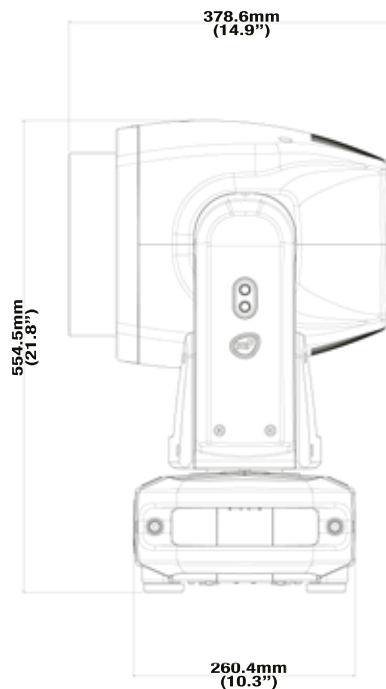

DTS' HQS (High Quality Spectrum) trademark certifies a product' **superior white light quality** and its ability to generate an **extended color palette** offering a wider gamut of **pastel-like shades** with rich warm nuances. A result achieved by a new **LED color generation mix** – compared to the standard RGBW – allowing a far more uniform distribution of energy along the visible light spectrum.

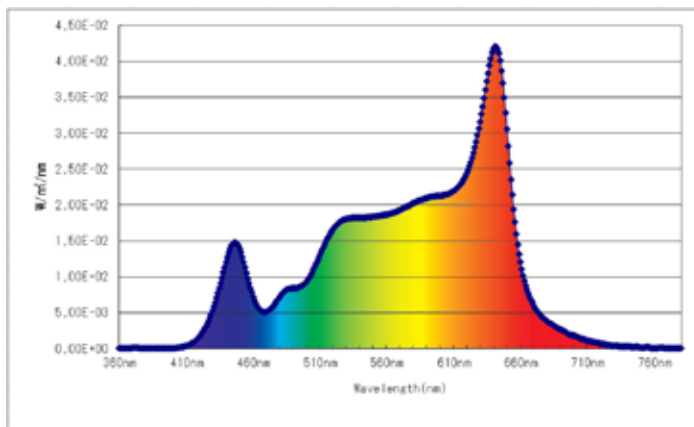

Measurement taken at 3200 K

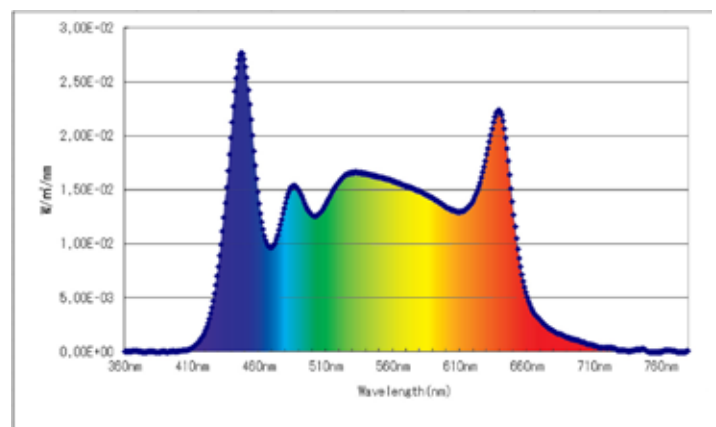

Measurement taken at 5600 K